



power quality solutions

LV Power Factor Correction
Static Var Generator, SVG
Harmonic Filtering
AC/DC Rectifier-Battery chargers

About Us

Established in the mid-80s, TELEGROUP was born from an idea by Fabiano Bagnoli, still today Managing and Technical Director of the Company. At that time, he was already founder of a well-known electrical installation company in the Chianti hills, more precisely in Sambuca, a worldwide symbol of history, art and culture.

From the start, TELEGROUP has been focusing its activity on the development, production and marketing of Low-voltage Power Factor Correction systems, which still represent the core business of the Company.

In just a few short years, thanks to the business strategy which was entirely concentrated on extremely high quality products, TELEGROUP successfully established itself in the Italian market as a synonym of reliability.

The will and perseverance within the Company to continually insist on quality has over the years been rewarded with numerous supplies to Italian and international end customers, leaders in their sectors who have chosen and have entrusted TELEGROUP with the development and implementation of LV PFC Systems for their plants.

Today, after thirty years of operations, TELEGROUP remains a dynamic, innovative company on the Italian and International electrical stage, with a Distribution Network able to cover over 40 countries worldwide.

In 2022, in order to consolidate its presence in the UK market, TELEGROUP formalized the opening of TELEGROUP PFC Ltd, a branch dedicated to the development of the UK market.



OVER
30 YEARS
OF EXPERIENCE



QUALITY
PRODUCTS



OVER
40 COUNTRIES
SERVED WORLDWIDE

International Presence and References

Our quality on the market

Thanks to its widespread distribution network, which includes 16 Agencies in Italy and over 25 partners abroad, TELEGROUP boasts the installation of its products in over 40 countries in through the 5 continents.

Ceramic industry, plastic industry, automotive, paper-mills, cement factory, Oil & Gas applications, are just some of the main application which we daily approach and where our power quality systems successfully operate.



Quality

Company certifications

TELEGROUP is a company certified in accordance with ISO 9001:2015, ISO 14001:2004, BS OHSAS 18001:2007, SA 8000:2014, issued by DNV, one of the most accredited certification bodies in the world.

All company processes, from design and procurement to production and testing up to sales and service, have been certified according to regulations and therefore represent further proof of the quality TELEGROUP process.

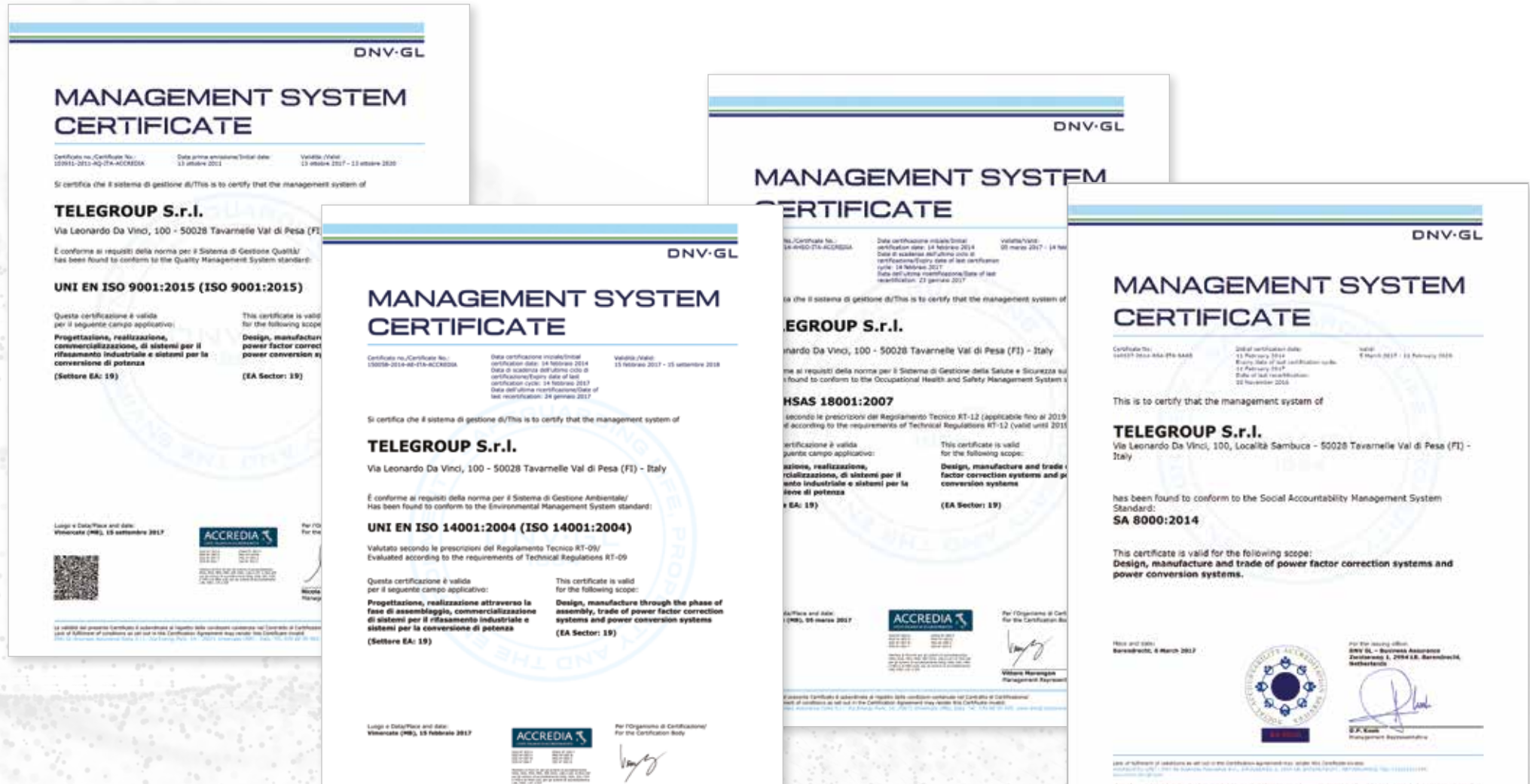

Product certifications

Following its internationalisation policy, TELEGROUP has over the years acquired multiple product certifications in order to meet the demanding requirements of foreign markets.

All products are designed and manufactured in compliance with international reference standards and, in particular, the entire TELEGROUP range of power factor correction systems is in compliance with:

EN 61921 EN 61439-1 IEC 60831-1 IEC 60831-2 EN 61642 EN 61000

TELEGROUP has carried out all the types of tests required by the KEMA laboratories for its low voltage power factor correction systems and in particular:

IEC 61439-1 par. 10.10 – required by TELEGROUP – Verification of resistance in a critical environment, **environmental temperature 52°C.**

IEC 61439-1 par. 10.11 – Verification of the resistance to short-circuit withstand current – 50 kA for 1 second – direct on busbars system, **not conditioned by a short-circuit protection device.**



CERTIFICATE OF CONFORMITY (SASO)

Acquired in 2015 for the power factor correction range, necessary for export to Saudi Arabia.

UL CERTIFICATION

Certification acquired on multiple occasions for the export of power factor correction systems in the American market.

Services

Network analysis

TELEGROUP makes use of its technicians and advanced technology equipment to carry out inspections and network analysis, especially in the most critical applications and subject to a greater presence of harmonic phenomena.

Commissioning

Assistance in panel start-ups, verification of current transformer positioning, illustration of Controller functions.

Special solutions

In addition to its standard product range, TELEGROUP designs and manufactures power factor correction systems with voltages from 230 V to 1000 V, 50 and 60 Hz, according to customer specifications.

Technical seminars

For years, technical meetings in collaboration with professional associations both in Italy and abroad have represented a key step in our activity.

Checking Electrical Bills

Verification of electricity consumption and penalties for excessive consumption of Reactive Energy imposed by Energy Distributors.



Product portfolio

LV Power Factor Correction systems

Improving the cosphi in the electric system, avoiding the penalties for excessive consumption of reactive energy, reducing the losses on power cables for Joule effect.



SVG, Static Var Generator

Installing a combined system, which could simultaneously operate as PFC system, for compensating the inductive or capacitive loads, and as active harmonic filter, for the reduction of harmonic contents in the electric system.



Active Harmonic Filter

Reducing the harmonic content - both in current and voltage - generates from distorting loads in the electric system, improving the efficiency.



AC/DC Rectifier - Battery charger

Protecting the auxiliary circuit of MV/LV substations, ensuring the continuity of service in the electric plant.



Nitrogen (n2) gas capacitors

Owning both types of insulation - Nitrogen and Oil - we are in a position to be able to express an impartial opinion for both technologies, highlighting their characteristics, and underlining that the quality of a capacitor doesn't determined neither by its insulation or its voltage, but rather by its production process and longevity of operation in the time.

Air/humidity infiltration inside the cylinder

Filling the cylinder with the Nitrogen (N2), a possible infiltration of air/humidity, is totally avoided.
in fact, the Nitrogen is the only filling that can be classified as "dry type" because it is in fact a dry gas, and therefore devoid of humidity.

Non-propagation of flame

The Nitrogen is a non-flammable gas, therefore also the risk of a probable fire due to the failure of a Capacitor is almost avoided.

The same cannot be fully guaranteed with the use of other fillings - Oil, Resin - more subject during the time to loss its insulation, causing a subsequent infiltration of air and a generation of internal electrical discharge, which generates a damage to the capacitor and possible fire, due to precisely to the characteristics of the insulation.

Filling process

1

Step 1

The windings (pre-assembled) are positioned in the cylinder.

2

Step 2

The (fixed) cover is positioned on the cylinder and wiring is inserted from the holes on the IP20 terminal.

3

Step 3

The capacitors are placed in the "drying chamber".

4

Step 4

2 terminals are welded, leaving only the central terminal open.

5

Step 5

The capacitors are filled with Nitrogen Gas (N2) from the central terminal, which is immediately welded.

3 YEARS warranty

g48

g48fix

g48filter

g48filter-fix

g48filter-T

... the approximately 9 million kVAr achieved in the last 15 years using Nitrogen Gas (N₂) Capacitors, and a fault report around 0 %, are certainly sufficient to be able for considering a product as reliable”

Strengthened by this case history, we are the only one company which currently offers a standard 3-year warranty on the entire equipment, for all panels equipped with Nitrogen (n₂) gas capacitors.

6

Step 6

The capacitors are placed in the “test room” to detect any possible gas leaks. The hermetic sealing is a measure that prevents leaks and testing checks the seal.

7

Step 7

Thanks to a special tracer gas, each individual capacitor is tested in conditions that far exceed the real leak conditions. We have not for the past 20 years have any reports in the field of moisture penetration or consequent loss of capacity.

Automatic Power Factor Correction Systems

Configuration

Transformer

for separating auxiliary circuits from power circuits.

Automatic PFC Controller

automatic Microprocessor with LCD display in 6 languages (PCRL) and 10 languages (PCRJ) for the insertion of capacitor banks.

Modbus protocol and remote control via RS232 and RS485 Serial Ports or Ethernet.

Busbar system

constructed through copper busbar system and 50 kA resistance for 1 s. PFCs with short-circuit resistance over 65 kA or also 80 kA for 1 s are available upon request.

Metal enclosure

painted with epossidic dust paint, standard external degree of protection IP31 (others up to IP54 upon request), internal degree of protection IP00 (IP20 with doors open on live parts).

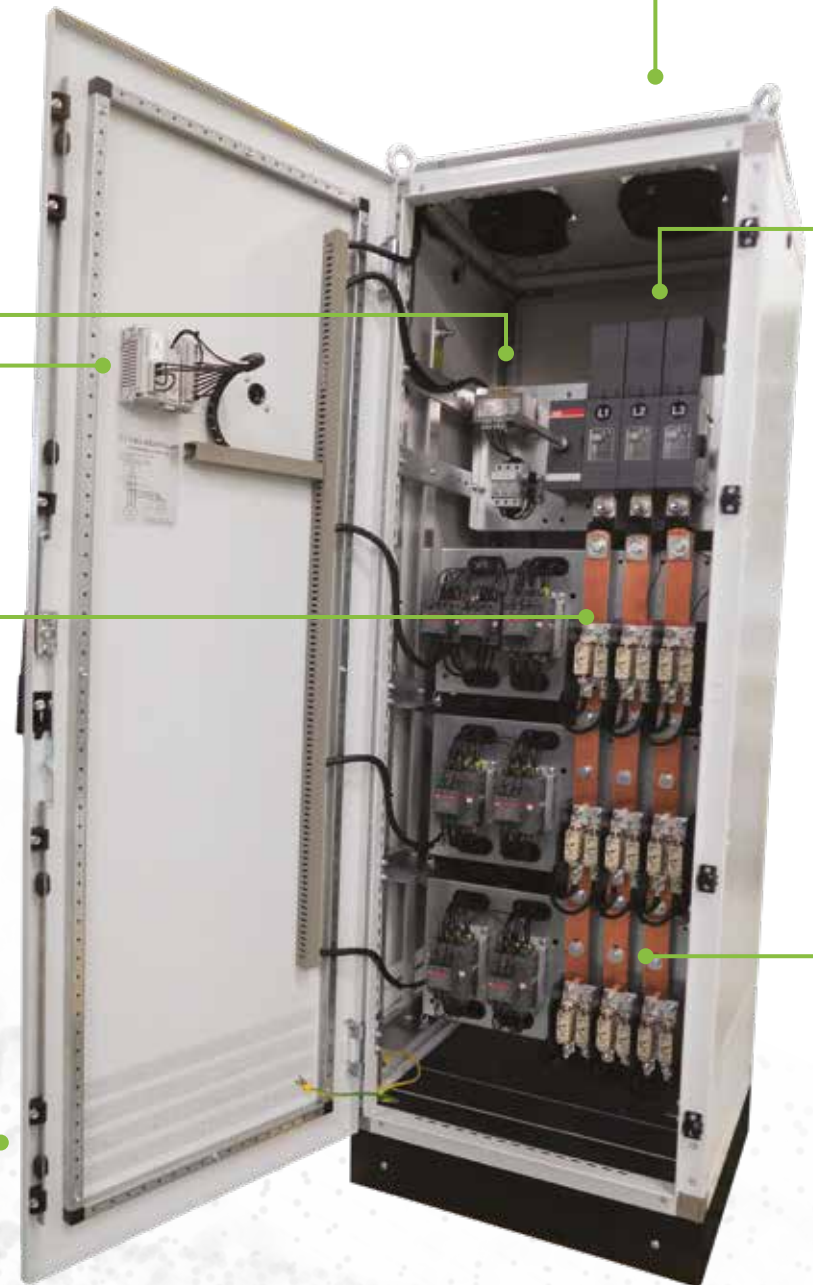

Ventilation System

Natural or Forced depending on powers and types. Forced Ventilation is achieved through one or more fans and thermostat or, in the case of an IP54 degree of protection, through a Suction Tower (IP54 Extractor).

Switch Disconnecter Device

Three-Pole Switch Disconnecter with door Interlock sized 1.5 times the nominal current of the Board. Switch Disconnectors with Fuses or MCCB can be installed upon request.

Modular Racks

Automatic PFC systems are realized in modular configuration, using modular racks (trays) connected with copper busbar system.

Three-phase Capacitors
with Oil or Nitrogen Gas (N₂)
insulation, depending on types.

Filter Reactors (if required)
made of a core of oriented crystal metal plate,
complete with thermal probe.
Tuning freq. (134 Hz, 189 Hz, 210 Hz)

**Three-Pole Contactors
or Thyristor Modules**

Protection fuses
NH00 100 kA

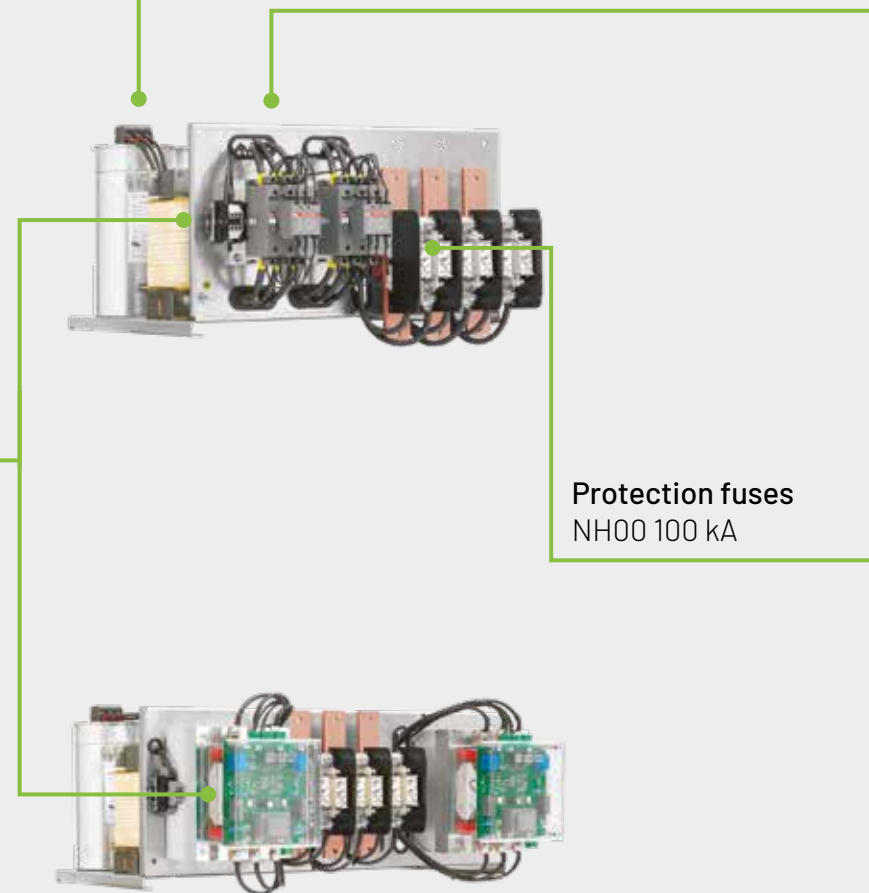

LV Power Factor Correction Systems

Solutions with Nitrogen (N₂) Capacitors

After more than 15 years from the first use, power factor correction systems equipped with three-phase Capacitors and Nitrogen Gas (N₂) insulation still today represent the core business of TELEGROUP.

The high quality and reliability of this technology have provided a decisive push for the creation of a whole range of products, from standard boards for small and medium users to large power modular systems for the energy-intensive industries.

G44 Series

Automatic PFC systems, Fix PFC systems, Modular racks



24 months warranty
on capacitors

G48, G48Filter series

Automatic PFC systems, Fix PFC systems, Modular racks, standard, detuned and thyristor switch version



3 years warranty
on the full system

Our capacitors can withstand the most severe work cycles (up to 30-35% of harmonic load in plants). That said, more than 20-25% of harmonic content could trigger parallel resonance phenomena between the Plant and the Power Factor Correction System with consequent stresses beyond the regulatory levels in both voltage and current. In these conditions, it is essential to use a Filter Reactor (CEI EN 61642).

g Series

Standard and custom-made solution

from 230 V to 1000 V in low voltage, 50 Hz and 60 Hz



Standard Automatic PFC systems

G44, G48 Series

Automatic systems for applications with medium harmonic content (THDi max 25%). Powers from 12.5 to 750 kVAR, Three-phase Nitrogen capacitors with voltage 440 V (G44) and 480 V (G48).

Automatic Systems with Filter Reactors

G48Filter, G48Filter-T Series

Automatic systems with 189 Hz (134 Hz upon request) Filter Reactors for applications with a high harmonic content in voltage and current to avoid the triggering of dangerous parallel resonance phenomena.

Powers from 18 to 750 kVAR (or higher powers upon request), Three-phase Capacitors in Nitrogen Gas with 480 V voltage and insertions through contactors. All panels are made with a modular system with 50 kA busbar system.

Fix PFC Systems

G44Fix, G48fFilter-Fix Series

Fix panels for vacuum power factor correction on MV/LV Transformers on Asynchronous motors. The G48FilterFix series is equipped with 189 Hz Filter Reactors.

Modular Racks

G44Rack, G48fFilterRack, G48fFilterRack-T Series

Modular Racks for the realization of Automatic systems, equipped with 50 kA busbar system, protection fuses, contactors or thyristors, 189 Hz filter reactors for the "detuned" series.

Optimal solution for the integration of the power factor correction bank inside low voltage panels.



LV Power Factor Correction Systems

Solutions with Three-phase Oil Capacitors

r Series



Parallel to the Nitrogen Capacitor range, TELEGROUP proposes the same solutions using three-phase capacitors with oil insulation. Although it does not have the same properties as nitrogen, this type is certainly the best known and also our company has used this type since its inception with excellent results. The wide range of types and powers allows for installation of the R Series boards both in small and medium users and in the most critical industrial applications.

Standard Automatic PFC Systems

R46 Series

Automatic systems for applications with medium harmonic content (THDi max 15 - 19 %). Powers from 12.5 to 750 kVAr, Three-phase Oil capacitors with voltage 460 V (R46).

Automatic Systems with Filter Reactors

R48Filter Series

Automatic systems with 189 Hz (134 Hz upon request) Filter Reactors for applications with both a high harmonic content in voltage and at risk of Resonance.

Powers from 18 to 750 kVAr, Three-phase Oil capacitors with voltage 480 V and insertions through contactors. All panels are made with a modular system with 50 kA busbar system.

Fix PFC Systems

R46Fix, R48fFilter-Fix Series

Fix panels for vacuum power factor correction on MV/LV Transformers on Asynchronous motors. The R48FilterFix series is equipped with 189 Hz Filter Reactors.

Modular Racks

R46Rack, R48fFilterRack Series

Modular Racks for the realization of Automatic systems, equipped with 50 kA busbar system, protection fuses, contactors or thyristors, 189 Hz filter reactors for the "detuned" series.

Optimal solution for the integration of the power factor correction bank inside low voltage panels.

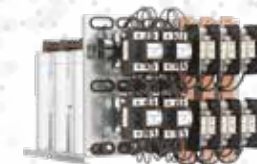

Automatic PFC Controller

In an Automatic Power Factor Correction System, the PFC Controller is, along with Capacitors, the essential element for the management and control of all the components.

Designed with advanced features, they combine a modern design with practical and intuitive functionalities.

Backlit LCD display with icons, alarm codes with scrolling texts, can be set in 6 languages (PCRL) and 10 languages (PCRJ).

Operation on 4 quadrants for cogeneration systems, drastic reduction in the number of switching, homogeneous use of equal power capacitor banks, reactive power measurement installed for each step, capacitor overcurrent protection, board over temperature protection by internal sensor, protection against micro breaks, wide range of available measurements, including voltage and current THD with analysis of the individual harmonics up to the 15th order.



KEY FEATURES

- ✓ Microprocessor control and management
- ✓ Intelligent auto adjustment
- ✓ Versions from 2 to 24 steps and up to 32 with Master-Slave function
- ✓ Versions with static outputs (PCRJ)
- ✓ Use in cogeneration and medium voltage plants
- ✓ USB, RS485, RS232, Ethernet communication interfaces Modbus RTU, ASCII e TCP communication protocols PROFIBUS communication protocol by adding an appropriate expansion module

Thyristor Modules

Thanks to the positive experiences gained with the use of this component, TELEGROUP decided to conduct thorough research and development, which led to the total internal production of Thyristor Modules.

This has allowed the company to obtain highly prestigious know-how, complete control over production steps and greater flexibility and competitiveness that drastically reduce the economic gap between insertion to Contactors and insertion to Thyristors.

Why Thyristor modules?

There are applications within Heavy Industry which, due to their operating cycle, tend to vary the load diagram in such a short time (from 1 to 5 seconds) and in some cases to such a high current peak (up to 20 In) that no contactor is able to follow and above all endure operation over time without becoming damaged.

The above conditions therefore require the use of Thyristor Modules for the insertion of Capacitor banks.

Advantages

- ✓ Capacitor bank insertion in times that can be estimated in milliseconds
- ✓ Increased Capacitor life
- ✓ Unlimited number of cycles

Applications

- ✓ Industrial welding machines
- ✓ Robotics
- ✓ Hydraulic presses
- ✓ Automotive systems



SVG, Static VAR Generator

AXG // Series

SVG is a totally electronic system, made with IGBT solid state technology, therefore in the total absence of mechanical parts, by a three-level inverter with an efficiency higher than 97%.

It is a system designed to operate in 3 different functions:

- ✓ Reactive power compensation
- ✓ Filtering of harmonics
- ✓ Phase balancing

Reactive power compensation is undoubtedly the fundamental feature of an SVG, as it is able to operate where a traditional power factor correction system would not be able to guarantee long-lasting service and reliability.

For example, all applications – mainly in heavy industry – with remarkably high harmonic contents, both in current and in voltage ($THDi > 80\%$ and $THDv > 15\%$).

SVG is available in 3 versions: Wall, Rack and Tower.



Principle of operation

SVG collects the load current trends over time in real time, sending them to an internal control circuit, via the use of Current Transformers. Through integrated FPGA technology, the fundamental components of the currents, the harmonic components, the reactive currents, the components responsible for the unbalance are extracted, the currents necessary for compensation and the compensation currents issued by SVG are also compared, and the difference is calculated.

In order to allow the IGBT inverter to be able to inject the necessary currents into the electrical grid, input signals are emitted to the driving circuit, so as to carry out closed-loop control and complete the compensation function.

Features

Quick touch-screen display for viewing network data.

- ✓ Current effective values of the load;
- ✓ THDi (current harmonic distortion) of the Load;
- ✓ Load power factor;
- ✓ Active, Reactive, Apparent power required by the load;
- ✓ Grid-side current and voltage effective values (after Power Factor Correction/Filtering);
- ✓ THDi and THDv (Current and Voltage Distortion) on the grid side;
- ✓ Grid side power factor;
- ✓ Active, Reactive, Apparent power on the grid side.
- ✓ Remote visualization through RS232 and RS485 serial port, Modbus protocol.
- ✓ The Currents and Reactive Powers injected by the equipment are also monitored.

Applications

- ✓ Heavy Industry (Metallurgical, Refineries ...)
- ✓ Data Center
- ✓ Cement plants
- ✓ Paper Mills
- ✓ Building Automation Systems
- ✓ Automotive Industry
- ✓ Waste Treatment Systems

How to choose an SVG system

The sizing of an SVG system depends on the type of function to which it will be subjected. In fact, in the case of power factor correction mode, the calculation of the necessary power in kVAr will be the same used for traditional power factor correction panels, while in the case of Active Filter mode the sum of the harmonic currents is required - whether it is a plant or a single load - obtainable through a network analysis. On the other hand, in the case of a combined system, with both power factor correction and harmonic filtering modes, a more in-depth evaluation is advisable, also depending on where the SVG system will be installed.

Active Filters

AXF // Series

The active filters of AXF series, have a very sophisticated energy quality control capability, able to filter harmonics up to the 50th order. Applicable in any condition both in the industrial and civil sectors, they represent the ideal solution for the treatment of non-linear loads.

Principle of operation

AXF picks up the current signal in real time through the CT, separating the harmonic part through the internal detection circuit. At the same time, it generates a compensation current, 180° out of phase with respect to the harmonic signals through IGBT power converters. The output current changes dynamically and precisely according to the harmonic content present in the network.



Benefits

- ✓ Almost zero maintenance // there are no electromechanical components
- ✓ Modularity // The system consists of parallelable rack modules up to 20 units (currents from 30 to 100 A)
- ✓ CT connection only the the "Master" unit.
- ✓ Advanced processing algorithm
- ✓ Maximization of operations and efficiency.

Features

- ✓ Quick touch-screen display for viewing network data
- ✓ Redundant operation: the system works even in case of failure of a unit.
- ✓ Harmonic residue $\leq 6 - 7\%$
- ✓ Remote control through RS232 and RS485 serial port, Modbus protocol.

Applications

- ✓ Heavy Industry (Metallurgical, Refineries ...)
- ✓ Data Center
- ✓ Cement plants
- ✓ Paper Mills
- ✓ Building Automation Systems
- ✓ Automotive Industry
- ✓ Waste Treatment Systems

How to choose an Active Filter

The sizing of an appropriate Active Filter, which is at the service of a plant or a single load, necessarily requires a thorough and accurate Network analysis of specific parameters. TELEGROUP, as well as for PFC systems, has offered this type of services for years through its specialized technicians.

AC/DC Rectifier Battery charger

ALM-S / ALM-D

The primary function of these devices, albeit in different methodologies, it's the same of an UPS, that is to guarantee the continuity of power supply. In fact, the only difference between an UPS and an AC / DC power supply unit is that the DC output voltage, instead of AC. Therefore, the use of these power systems is attributable to the same fields of application of the UPS, whose purpose is to ensure continuity of service, in order to avoid substantial damage at an electrical, economic and safety level.

The TELEGROUP range includes solutions for single-branch solutions of the ALMS Series, in addition to the double branch versions of the ALMD Series; all the series can be realized with single or three-phase input voltage, 24 Vdc output, 48 Vdc or 110 Vdc.

Key features

- ✓ IGBT chopper technology
- ✓ Input isolation Transformer*
- ✓ Display on front panel
- ✓ Compact cabinet

*for systems with 3-phase input

Input

Rated voltage 230 Vac 1-phase ($\pm 20\%$) / 400 Vac 3-phase ± 10 (others on request)
 Rated Frequency 50 - 60 Hz

Output

Rated Voltage 24 Vdc, 48 Vdc, 110 Vdc
 Voltage stability with
 and without gris supply 0,9 Vn (total discharge of batteries) / 1,13 Vn (total charge of batteries)
 Rated current from 25 to 60 A (others on request)
 Voltage ripple < 1 %

Applications

- ✓ Auxiliary circuits on MV/LV substations
- ✓ Emergency lighting
- ✓ Industrial applications
- ✓ Telecommunication systems



Operating diagrams

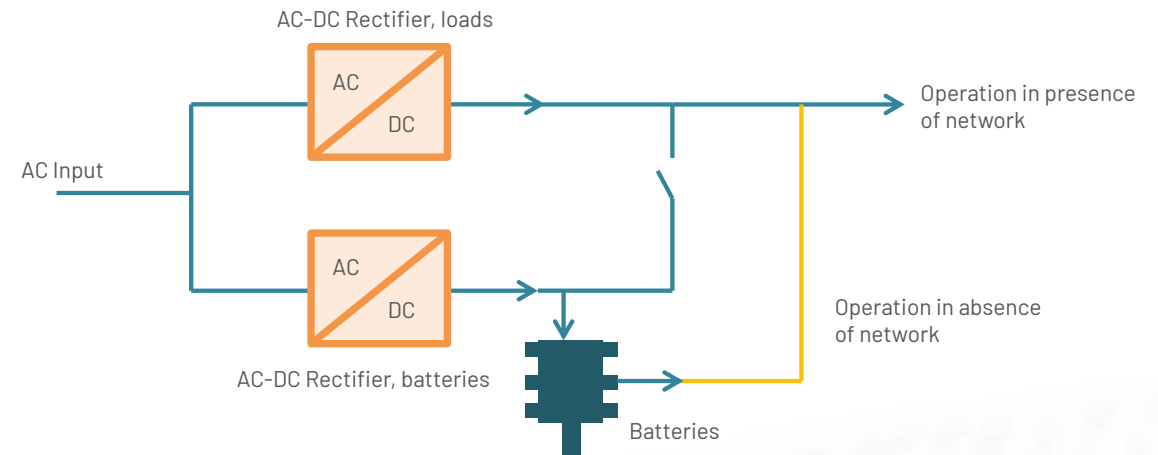
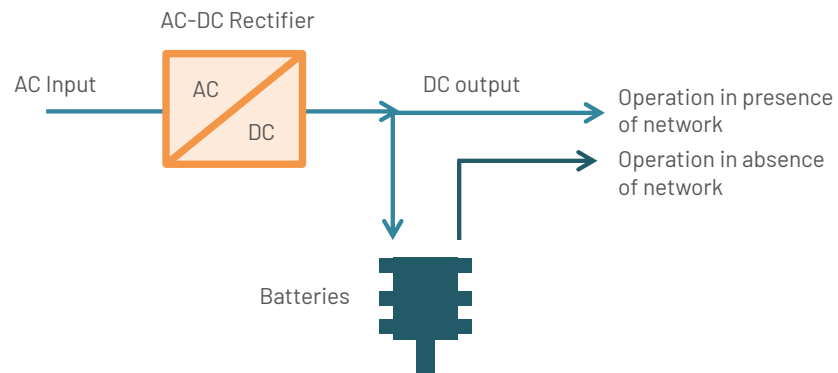

Technical features

Rectifier	IGBT chopper technology
Display on front panel	Voltage for loads and batteries Current for loads and batteries Voltage of batteries Status of loads and batteries
Batteries	VRLA, GEL (installed internally)
Cabinet	Steel enclosure, painted with epoxy dust paint
Colour	RAL7035
Protection degree	IP31 internal (IP42 and IP54 on request)
Input of cables	Standard from the top (from the bottom on request)
Cooling	Natural
Installation	Indoor
Max altitude	1000 m a.s.l.
Relative humidity	< 90% without condensing
Operating temperature	0°C / +40°C
Storage temperature	-25°C / +70°C (excluding batteries)
Reference standards	IEC62040-1, IEC62040-2, IEC62040-5-3, IEC478-1

Optionals

- ✓ KITALL Kit Alarms; terminal board with voltage-free contacts for remote alarm of general fault, power failure and low voltage of batteries.
- ✓ KITSGB Kit for disconnection of batteries at minimum voltage; in the absence of network beyond the required autonomy, the kit will disconnect the batteries, to prevent their complete discharge, which would irreversibly compromise their use.
- ✓ KITISL Insulation control kit (earth pole) in case of short circuit or other malfunction.
- ✓ KITPAR Parallel kit; provision for connection of a system with equal characteristics for parallel operation.
- ✓ KITEPO** EPO kit (Emergency Power Off), with release button.
- ✓ KITMCB MCBs on front panel (on request).

**bound to purchase also KITSGB



TELEGROUP S.R.L.

Via Leonardo Da Vinci, 100

50028 Tavarnelle Val di Pesa, Loc. Sambuca - Florence, Italy

Phone: +39 055 80 71 267 / 118 - Fax: +39 055 80 71 338

sales@telegroup.it

www.telegroup.it